

Rotary Table System Series HRT-105

Innovative design for highest dynamic and precision



Compact design



Highest torque density

Smaller packing means lowering footprint



Low cogging value

Smooth motion and positioning accuracy



No backlash

Highest stiffness



Integrated measuring system

Incremental or absolute value encoder, different types

Rotary table - ready to install

Mechanically & electrically ready for connection

M17 connectors

Direct drive

Precise & no backlash

Innovative design

Reduced moving mass for low inertia

Low cogging value

Smooth running characteristics

Customer specific modifications possible

Use with servo amplifiers:

ECOVARIO® 414

ECOVARIO® 415D

Field bus interfaces:

CANopen, EtherCAT, Profibus, Profinet, Ethernet, RS232, RS485

Rotary Table System Series HRT-105

→ Technical data

		Series HRT-105-17	Series HRT-105-25	Series HRT-105-34
Rated Values		(preliminary)		(preliminary)
Max. rated DC link voltage	V _{DC}	325	325	325
Peak torque (c.d.f. 5%) ¹⁾	Nm	2,9	6,6	10,5
Maximum speed ²⁾	min ⁻¹⁾	500	500	500
Rated torque ¹⁾	Nm	0,7	1,6	2,7
Max. current (per phase, c.d.f. 5%) ¹⁾	A _{RMS}	14,0	14,0	14,0
Rated current (per phase) ¹⁾	A _{RMS}	3,2	2,9	3,6
Repeatability ²⁾ with encoder incremental / absolute	arcsec	±3 / ±5 (±2,5) ⁵⁾	±3 / ±5 (±2,5) ⁵⁾	±3 / ±5 (±2,5) ⁵⁾
Radial eccentricity	standard	µm	t.b.d.	< 25
	optional	µm	t.b.d.	< 10
Axial eccentricity	standard	µm	t.b.d.	< 25
	optional	µm	t.b.d.	< 10

Technical Data Motor

Torque constant	Nm/A	0,22	0,55	0,75
Voltage constant	V/1000min ⁻¹	18	37,5	65
Winding resistance	Ω	2,8	4,1	6
Winding inductivity	mH	5,2	7,6	16,0
Number of pole pairs	2p	10	10	10
Motor inertia	kgm ² x10 ⁻³	0,14	0,22	0,3
Max. axial load	N	100 ³⁾	100 ³⁾	100 ³⁾
Max. radial load	N	100 ³⁾	100 ³⁾	100 ³⁾
Topple torque	Nm	5 ⁴⁾	5 ⁴⁾	5 ⁴⁾

Incremental Encoder

Resolution (standard) ²⁾	inc/rev	532 000	532 000	532 000
Resolution (maximum) ²⁾	inc/rev	972 800	972 800	972 800
Operating voltage	V _{DC}	5 (±10%)		
Signal specification		RS422		

Absolute Value Encoder

Resolution (standard)		18 Bit	18 Bit	18 Bit
Resolution (maximum) ²⁾		20 Bit	20 Bit	20 Bit
Operating Voltage	V _{DC}	5 (±5%)		
Protocol		BiSS C		

Environmental Conditions

Ambient temperature		0 ... 40 °C		
Temperature switch-off sensor		PTC , 105 °C		
Protection class		IP40		

1. Mounting flange 250 mm x 250 mm / thickness 20 mm
2. Depends on the measuring system
3. speed: 300 min⁻¹, a higher individual load leads to a limitation of the bearing life
4. speed: 300 min⁻¹ with maximum load, different application must be calculated
5. under preparation

Characteristic HRT-105-17/ECOVARIO® 414

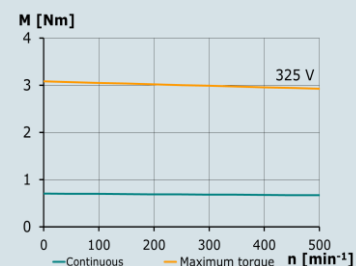

Characteristic HRT-105-25/ECOVARIO® 414

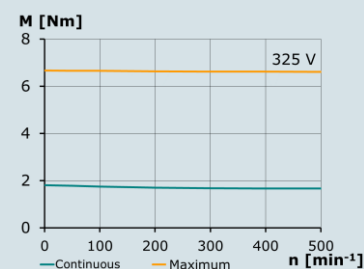

Characteristic HRT-105-34/ECOVARIO® 414

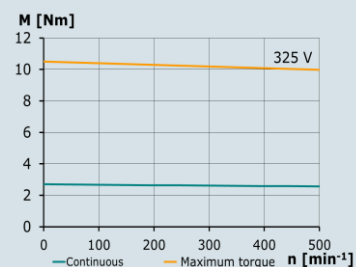

Rotary Table System Series HRT-105

→ Dimensions

		Series HRT-105-17	Series HRT-105-25	Series HRT-105-34
Outer diameter	mm	120	120	120
Height	mm	35	37	46
Weight	kg	1,1 / 1,3*	1,4 / 1,6*	1,9 / 2,1*

*) with option "Improved radial and axial run-out"

HRT-105-25:

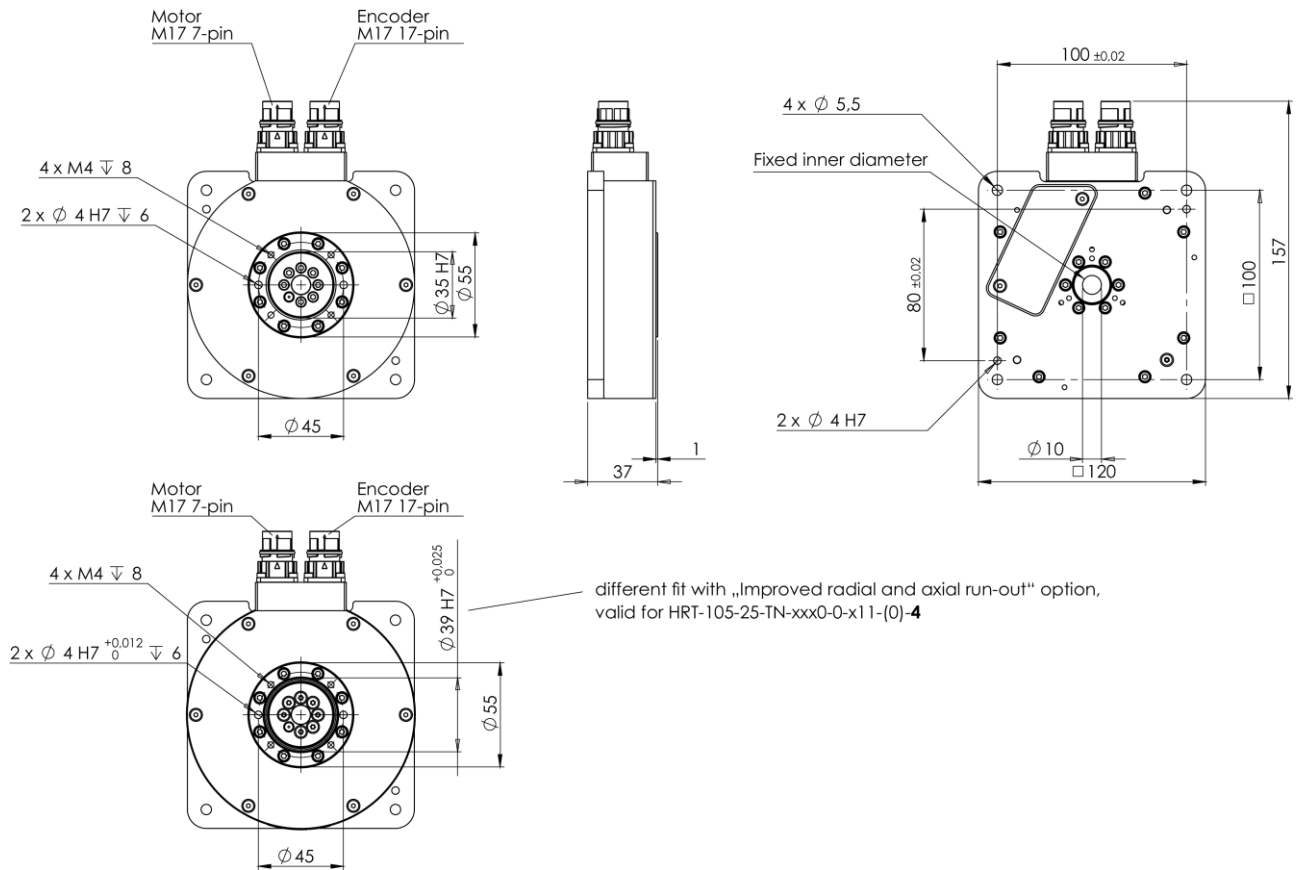

→ Ordering key

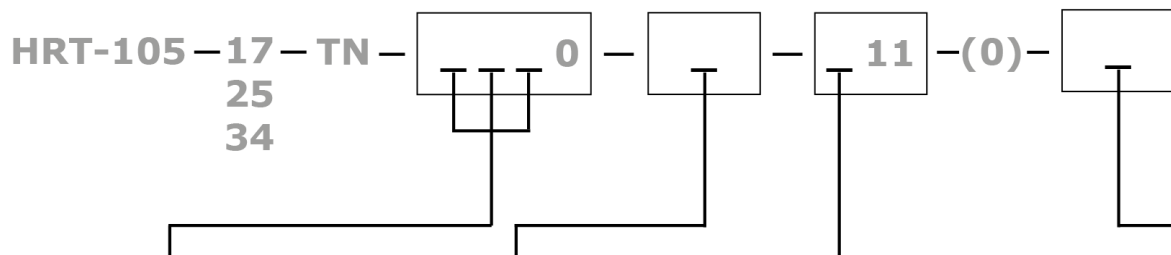

Measuring system	
500	Increment. 532 000 inc/rev
E04	Absolute 18 bit
E14	Absolute 20 bit *
*) under preparation	

Holding brake	
0	Without brake

Connector outlet	
R	Radial (default)
A	Axial

Option	
2	Default
4	Improved radial and axial run-out

Rotary Table System Series HRT-105

→ Accessories

Mating connector set 70.070 (for cables made by customer)

Motor mating connector M17

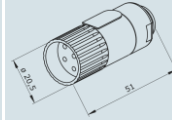

Encoder mating connector M17

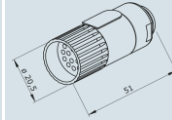

Cable assemblies

Motor cable (for ECOVARIO® 414)
MOT61-133-523-0xx-100

Ø 8,2 mm; trailing capability from bend radius > 80 mm

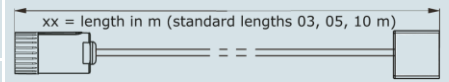

Motor cable (for ECOVARIO® 415D, 616)
MOT67-133-523-0xx-100

Ø 8,2 mm; trailing capability from bend radius > 80 mm

Incremental encoder cable (ECOVARIO® 414)
INK65-491-525-0xx-000

Ø 9,5 mm; trailing capability from bend radius > 90 mm

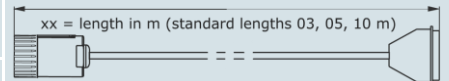

Incremental encoder cable (ECOVARIO® 415D, 616)
INK65-305-525-0xx-000

Ø 9,5 mm; trailing capability from bend radius > 90 mm

Absolute encoder cable
ABS65-300-525-0xx-000

Ø 9,5 mm; trailing capability from bend radius > 90 mm

→ Connector and cable assignment

Assignment motor cable

Connection	Motor connector pin M17	Motor cable wire MOT61	Motor cable wire MOT67
Phase U	4	3	1
Phase V	1	1	2
Phase W	5	4	3
PE	7	gn/ye	gn/ye
Shield	Housing	Shield	Shield

Motor connector:

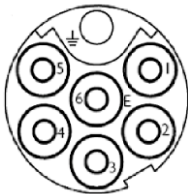

Encoder connector:

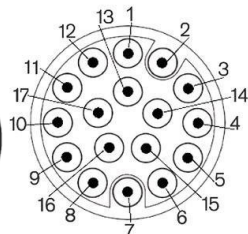

Assignment incremental encoder cable

Connection	Encoder conn. pin	Encoder cable wire	Pin D-Sub 9 pin /HD 15 pins
+5V	15	brown	1
GND	16	white	6
Channel A	1	green	2
Channel /A	2	yellow	7
Channel B	3	grey	3
Channel /B	4	pink	8
Channel N	5	blue	4
Channel /N	6	red	9
PTC	7	violet	5
PTC	8	black	6 / 10
Shield*	Housing	bare	Shroud

Assignment absolute encoder cable

Connection	Encoder conn. pin	Encoder cable wire	Pin D-Sub HD (15 pins)
+Up	13	brown	1
GND	16	white	6
Channel CLK	11	green	14
Channel /CLK	12	yellow	15
Sens S-	17	grey	11
Sens S+	14	pink	12
Channel DAT	9	blue	4
Channel /DAT	10	red	9
PTC	7	violet	5
PTC	8	black	10
Shield	Housing	bare	Shroud

*) D-Sub HD 15 pins: additional bridges in connector, double shielding