

# Measuring Microscope VMM150

---



Revision No: 04

Precise measuring microscope with binocular or video tube and brilliant optics, hand driven or motorized.



Technische  
Mikroskopie

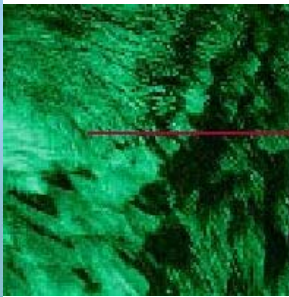

## Measuring all and Seeing all

### Highest accuracy in measuring

- Optical inspection, i.e. non-contact inspection of sizes and forms of metal, plastic and ceramic parts.
- Optical inspection also includes the force-free measuring test of deformable parts e.g. rubber.
- Usable for checking primary samples, spot tests and even up to series inspection of moulds, bended and diecasting parts.
- Inspection of profile gauges, templates, cutting tools, springs etc.
- 0.0001 mm resolution of measured values.
- Incremental steel linear scales.
- Fast and fine adjustment of the measuring stage.
- Transmitted and coaxial incident light plus additionally oblique incident light.
- Stepless brightness control integrated in the instrument.

### The VMM 150 detects everything

- Changeable micro objectives for up to 1000x magnification.
- For metallurgical examination, plus the observation of material fractures.
- Coaxial incident light provides the perfect illumination.
- Different tube variants are available:
  - binocular measuring tube with exchangeable field inserts for graticules or
  - binokularer Messtubus mit Videoadapter
- The VMM 150 is universally applicable in
  - The production of sub-contracting parts for the automobile industry.
  - IProduction branches of electrical engineering and electronic industry.
  - IAeronautical and aerospace industries, test laboratories, universities etc.
  - Research and development divisions of the different industries.

### Top – the performance

- Untiring work since viewing with both eyes.
- Guided roll-bearing X/Y stage with a measuring range of 150 x 100 or 200 x 100 mm.
- Optical system with telecentric ray path.
- Optional Z measuring system.
- Exchangeable objectives.
- Upright and laterally true image.
- Opto-electronic measuring system with a failure-free readable numerical display.



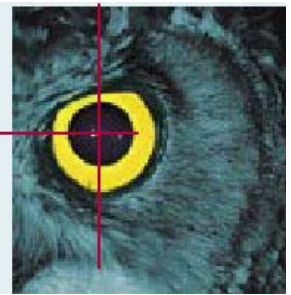

## Processing of measured values

The matching software for each application.

- **MX230**

The compact digital read-out unit with display of 3 axes and integrated calculating functions without image processing for quick measurements in the shopfloor.



- **Metlogix M2**

Advanced multi-touch application on a tablet PC for 2-4 axes. Clear user interface with displays and symbols. Digital read-out, graphical part view and report with tolerance evaluation and comprehensive data export facilities are the main features.

Can be used with manual microscopes.

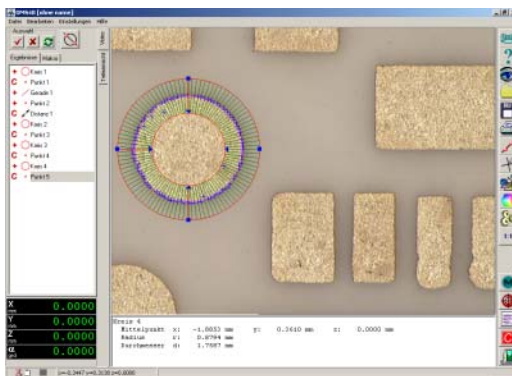

- **OMS**

The flexible, easy-to-learn measuring software from UHL; ideally for measuring of first-off samples and small batches. Flexible on-screen masks and measuring lines (distance / angle) for easy visual inspection. Multiple measuring tools with automatic edge detection

Can be used with manual and motorized microscopes.



- **Metlogix M3**

Enhancement of the M2 software with imaging functions. Elements can be measured just by fingertip on the touch screen or classically by mouse.

Can be used with manual and motorized microscopes.

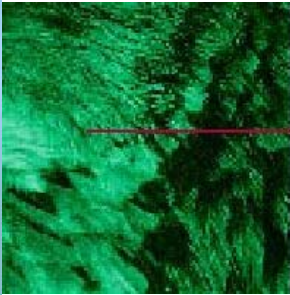

## Introduction

### Special Accessories

- Field inserts with crosshair and concentric circles for radius measurements.
- Angle measuring insert with digital measuring system (Q).
- Micro optical attachment for micro objectives.
- LED ring light illuminations.
- Swiveling plates and centre supports.





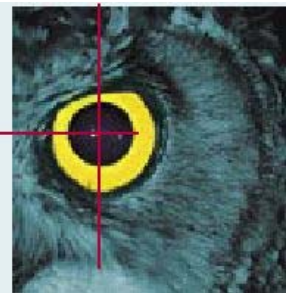

### UHL Measuring Microscope VMM150 with binocular measuring tube (without digital read-out)

| Consisting of following components:   | Order No. | VM3-BT01         |
|---|-----------|------------------|
| 1 Main unit with vertical column and height adjustable binocular tube, integrated coaxial incident and transmitted LED illumination with brightness control |           | VM3-005          |
| 1 Graticule slide with crosshair and 2 additional lines at $\pm 60^\circ$   |           | VM4-301          |
| 1 Measuring stage, measuring range 150 x 100 mm, with opto-electronic measuring system, cable for signal transmission, fast and fine adjustment             |           | VM3-602          |
| 2 Eye-pieces, 10x magnification, with eye cups,<br>Order no. for one piece  |           | WF10XL           |
| 1 Measuring objective 2:1,<br>free-working distance 85 mm   |           | OP1-M02          |
| similar to VM3-BT01, but with motorized measuring stage KT6-MSMA, measuring range 200 x 100 mm  |           | <b>VM3-BT01M</b> |



### UHL Measuring Microscope VMM150 with video measuring tube (without digital read-out)

| Consisting of following components:   | Order No. | VM3-VT01            |
|---|-----------|---------------------|
| 1 Main unit with vertical column and height adjustable video tube, integrated coaxial incident and transmitted LED illumination with brightness control |           | VM3-006             |
| 1 Measuring stage, measuring range 200 x 100 mm, with opto-electronic measuring system, cable for signal transmission, fast and fine adjustment         |           | KT6-MHTA<br>VM4-USB |
| 1 High resolution USB color camera  |           |                     |
| 1 Measuring objective 1:1,<br>free-working distance 88 mm   |           | OP1-M01             |
| similar to VM3-VT01, but with motorized measuring stage KT6-MSMA, measuring range 200 x 100 mm  |           | <b>VM3-VT01M</b>    |
| similar to VM3-VT01, but with motorized measuring stage KT6-LSMA, measuring range 150 x 100 mm  |           | <b>VM3-VT02M</b>    |



### Measuring system for coordinate direction Z

Opto-electronic measuring system for coordinate direction Z, incremental-divided scale, resolution 0.0001 mm

Order No.

**VM3-101**



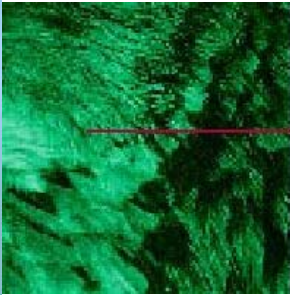

## Digital read-outs



### Digital read-out unit MX230

3-axis digital read-out with alphanumerical and graphical display, calculating functions for geometrical combination of the measured values, serial RS232 and USB interface

Possibility to connect either a Z-axis or a Q-axis (configurable by software)

Order No.

**MX230**

### Programmable Measuring Functions

|  |  |  |  |  |  |  |  |
|--|--|--|--|--|--|--|--|
|  |  |  |  |  |  |  |  |
| <ul style="list-style-type: none"> <li>• Measuring without manual calculation.</li> <li>• No mechanical work-piece alignment owing to the calculated transformation of coordinates.</li> <li>• Measuring of circle diameters with 3 to 50 points.</li> <li>• Right-angled cartesian and polar coordinate systems.</li> </ul> | <ul style="list-style-type: none"> <li>• Combination of up to 50 measured values per geometrical element.</li> <li>• Location of origin points upon user's choice.</li> <li>• PRESET function</li> <li>• Graphical display of geometry elements</li> </ul> |  |  |  |  |  |  |



## Digital read-outs

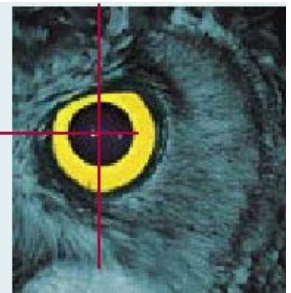

### Digital read-out unit M2

Measuring software M2 on tablet computer for 2 axes with tablet holder

**Order No.**

**M2-2TD**

Measuring software M2 on tablet computer for 2 axes with tablet holder and additional Q-axis angle field insert VM4-302

**M2-2TDQ**

Measuring software M2 on tablet computer for 3 axes with tablet holder

**M2-3TD**

Measuring software M2 on tablet computer for 3 axes with tablet holder and additional Q-axis angle field insert VM4-302

**M2-3TDQ**



### Video measuring software M3

*hand-driven instruments*

**Order No.**

Measuring software M3 on All-In-One PC with light control and USB counter for two axes

**M3-2HAD**

Measuring software M3 on All-In-One PC with light control and USB counter for three axes

**M3-3HAD**

*motorized instruments*

Measuring software M3 on All-In-One PC for three axes (details see next page)

**M3-3MAD**

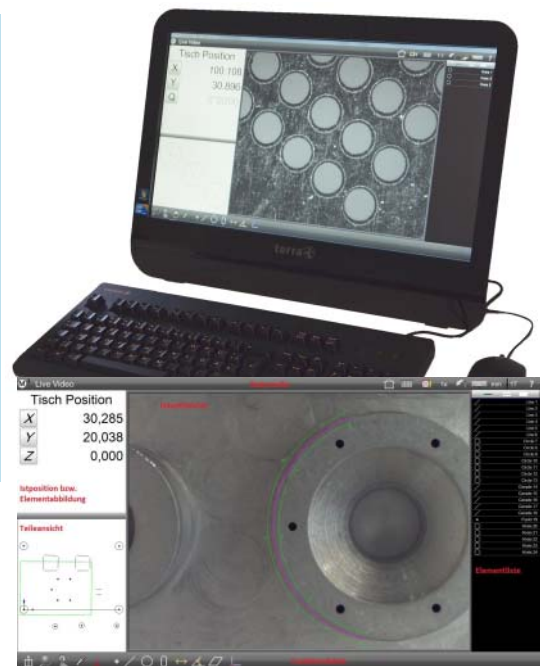

### UHL measuring software OMS

*hand-driven instruments*

**Order No.**

Measuring software M3 on All-In-One PC for three axes, with USB counter, with light control

**OMS-HADL**

*motorized instruments*

Measuring software OMS on Desktop-PC for three axes (details see next page)

**OMS-MDDL**

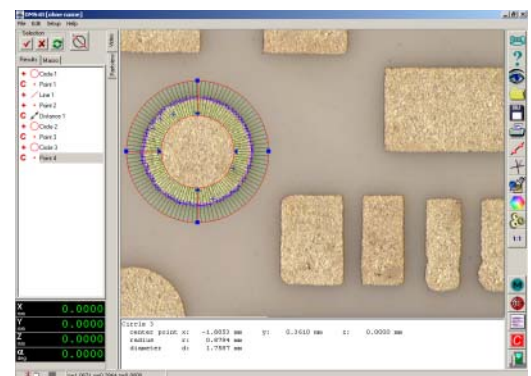



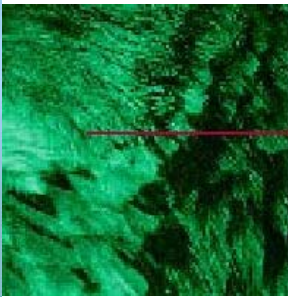

## Video Measuring Software

### OMS

The flexible, easy-to-learn measuring software for two dimensional measurements of primary samples and small batches by either hand-operated or motorized-operated measuring microscopes, for use in laboratories or production areas.

- Element-related combination of geometrical forms in a tree structure.
- Simple manual placement of the measuring points in the video image via the mouse.
- Immediate result display in a text protocol.
- Easy in memorizing or programming of measuring sequences and additionally the possibility of automated edge findings.
- Rectangular, circular, lattice and interactive image screen masks can be created as measuring frames for quick, visual control.

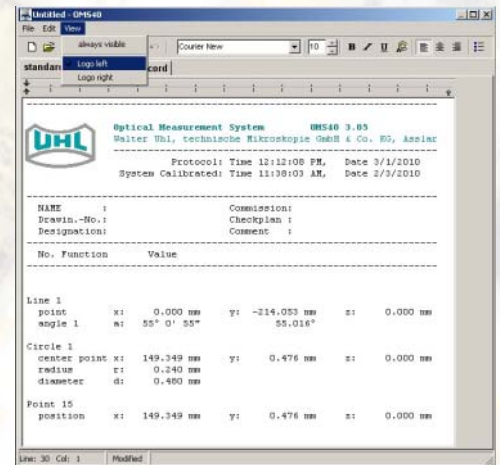
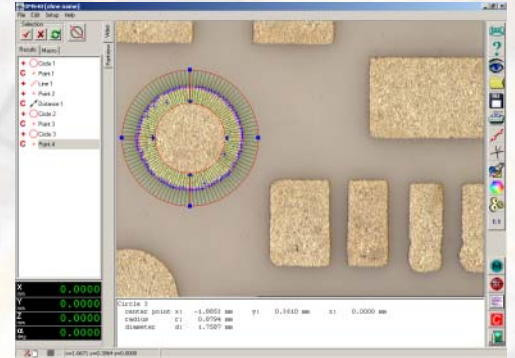

### Measuring Software System UHL OMS Complete system for 3 axes

Order No. **OMS-MDDL**

consisting of following components:

- 1 Desktop-PC with a 19 " TFT monitor
- 1 Software Package OMS
- 1 3-axis stepper motor control system with Joystick
- 1 calibration graticule

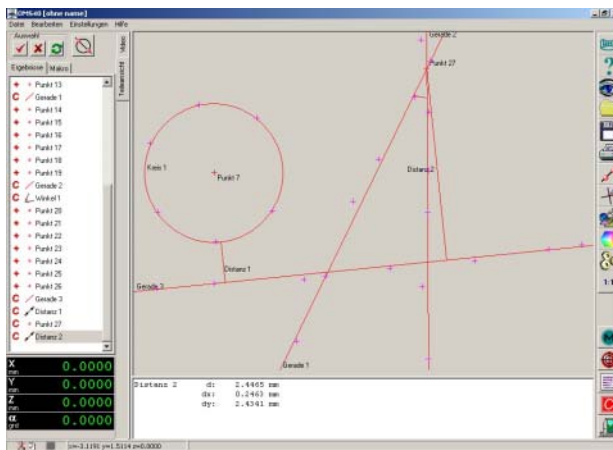
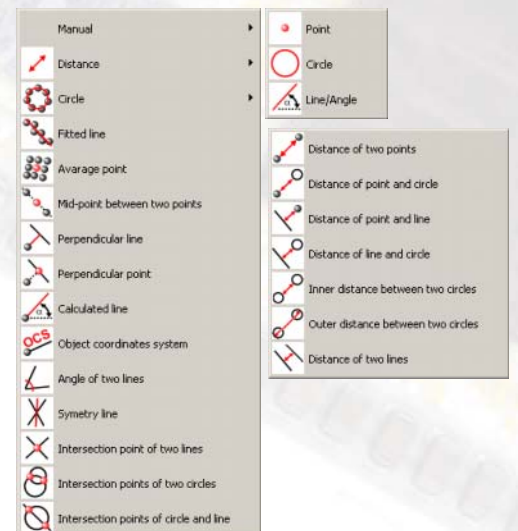



# Video Measuring Software

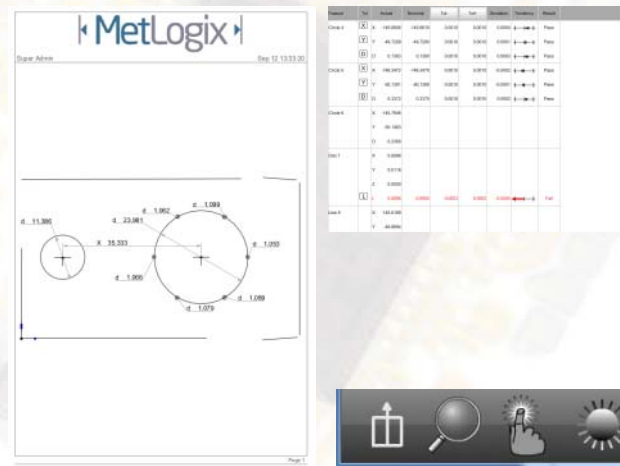
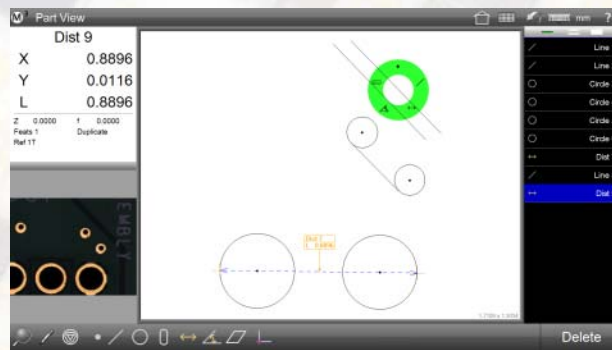
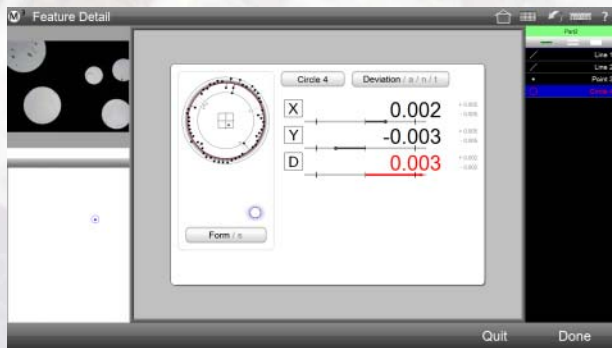
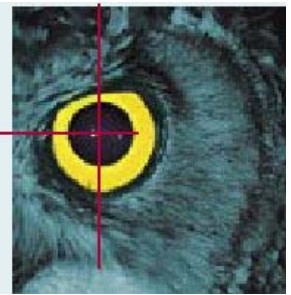

## Metlogix M3

- comes with following standard functions:

- Intelligent imaging functions to measure regular 2D geometry elements
- Combinations and relations from measured elements
- Leveling and alignment functions
- Part programs
- Tolerance evaluation according to Din/ISO
- Multiple coordinate systems
- Multilingual
- Data export and printout with graphic
- Dimensioning of the part view
- Image export with/without measuring result
- DXF module to compare the measurements with the drawing, good/bad evaluation
- Light control
- Optimal edge detection by „Measure Logic“ or active/fixed crosshair

## Measuring software system Metlogix M3 Complete system for 3 axes

Order No. **M3-3MAD**

consisting of following components:

- 1 All-In-One PC with touchscreen and the software Metlogix M3
- 1 Motion controller for 3 axes
- 1 calibration graticule

*optional:*

DXF module to compare the measurements with the drawing, good/bad evaluation

**M3.DXF**



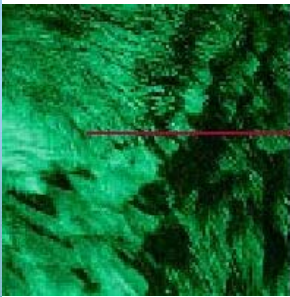

## Accessories

### UHL Measuring Microscope with Binocular Measuring Tube

A video camera with C-mount connector can be assembled when using one of the following adaptors.

#### C-Mount Adapter with 1.2x magnification

Order No. **VM4-410**

consisting of following components:

|   |         |
|---|---------|
| 1 Video adapter with 1.2x magnification | VM4-400 |
| 1 C-Mount camera connecting piece       | VM4-402 |

#### C-Mount Adapter with integrated magnification changer

Order No. **VM4-411**

consisting of following components:

|   |         |
|---|---------|
| 1 Video adapter with integrated magnification changer 0.4x / 1.2x, suitable only for 1/1.8" cameras | VM4-401 |
| 1 C-Mount camera connecting piece   | VM4-402 |

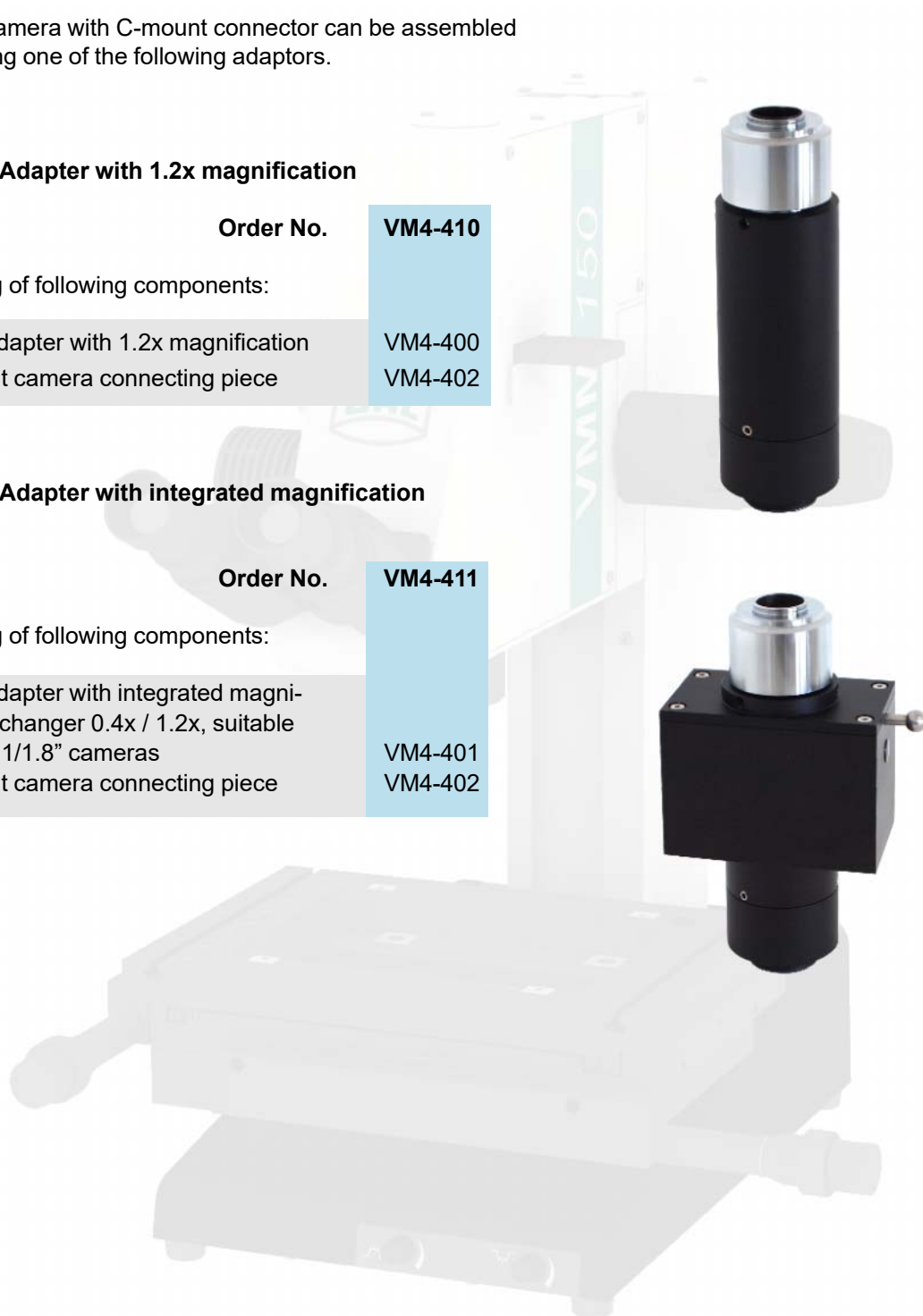

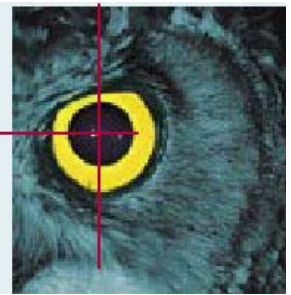

**USB digital color camera**

**Order-No.**

Digital cameras for the c-mount adapters (not included) to store images or view live picture (required for OMS or M3 software).

USB 3.0 interface

incl. PC-software for the image acquisition

1/1.8" resolution: 2048x1536 pixel (suitable for VM4-410 + 411)

**VM4-USB**

1" resolution: 2592 x 2048 Pixel (suitable for VM4-410)

**VM4-USB5**

*optional:*

Easy software to measure samples in the video image, movable video scale with distance measurement, images can be watermarked and saved with a comment.

**OMS-LT**

OMS is available in german or english.

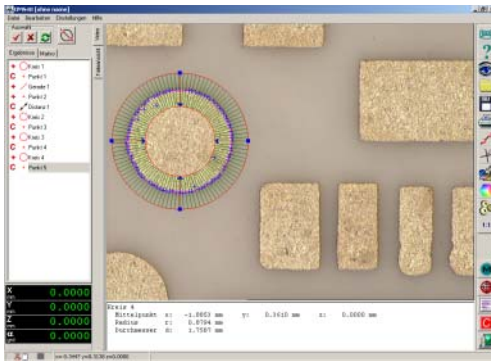

**Swiveling stage plate**

**Order-No. VM3-611**

For product alignment on the stages VM3-602 and KT6-LSMA

swiveling range:  $\pm 3^\circ$



**Centre supports**

**Order-No.**

To fix turned parts on the stages VM3-602 and KT6-LSMA  
optional with swiveling

**VM4-611  
VM3-612**



Revision No: 04



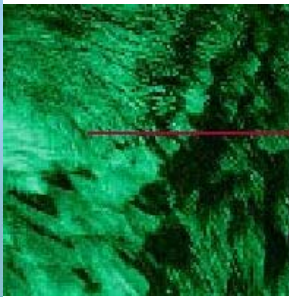

## Accessories

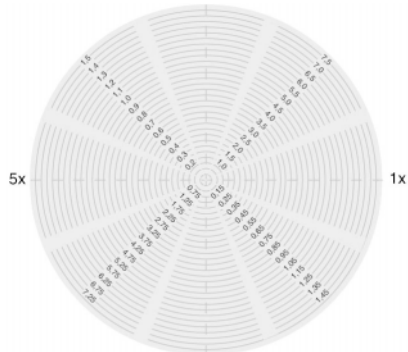

### Field insert with crosshair and concentric circles

Order No. **VM4-304**

Crosshair 90° with 2 additional lines  $\pm 60^\circ$  as well as each 2 sets of 30 concentric circles

Usable in conjunction with binocular measuring tube VM3-303

| Total magnification | Diameter        | Increments |
|---------------------|-----------------|------------|
| 10x                 | 0.25 to 7.50 mm | 0.250 mm   |
| 20x                 | 0.25 to 3.75 mm | 0.125 mm   |
| 50x                 | 0.05 to 1.50 mm | 0.050 mm   |
| 100x                | 0.05 to 0.75 mm | 0.025 mm   |



### Angle measuring insert with digital measuring system

Order No. **VM4-302**

Rotatable crosshair combined with optoelectronic measuring system, based on an incremental-scale, usable in conjunction with binocular measuring tube





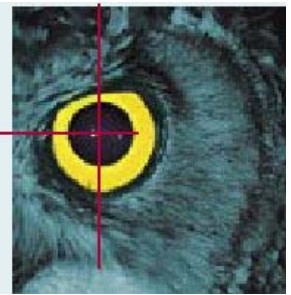

**Measuring objectives**

Telecentral measuring objectives of highest quality *designed by LEICA*, perfectly corrected, plane and distortionless images allowing a definable and precise edge detection.

Large working distances for measuring test objects e.g. disturbance edges or in bore holes.

Easily and quickly changeable secured fixing via the bayonet mount.



| Lens magnification | Total magnification | Object-field diameter | Numerical aperture | Free-working distance | Sharpness depth | ~ Probing accuracy | Order-No. |
|--------------------|---------------------|-----------------------|--------------------|-----------------------|-----------------|--------------------|-----------|
| 1 : 1              | 10-fold             | 20 mm                 | 0,03               | 88                    | 0,3             | 5                  | OP1-M01   |
| 2 : 1              | 20-fold             | 10 mm                 | 0,06               | 85                    | 0,08            | 3                  | OP1-M02*  |
| 5 : 1              | 50-fold             | 4 mm                  | 0,13               | 62                    | 0,02            | 1.5                | OP1-M05   |
| 10 : 1             | 100-fold            | 2 mm                  | 0,20               | 52                    | 0,01            | 1                  | OP1-M10   |

\* Measuring objective 1:1 or 2:1 included in basic version of UHL Measuring Microscope VMM 150.

Revision No: 04



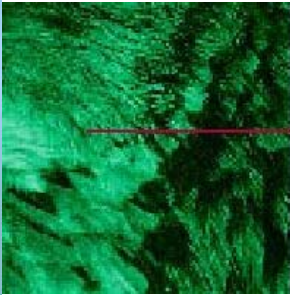

## Accessories

### Ring Light - Illumination Unit

Order No. **VM4-506**

Suitable for all OP1-M measuring objectives

For use in connection with cold light source VMP-GLL

add-on devices:

Set of polarisation filters

**RL2.09**

Diffusor

**RL2.10**

Segment aperture

**RL2.11**



### Automatic LED Cold Light Source

Order No. **VMP-GLL**

Hand- or computer-driven (by USB),  
approx. 640 lumen,  
stepless brightness control  
with field insert



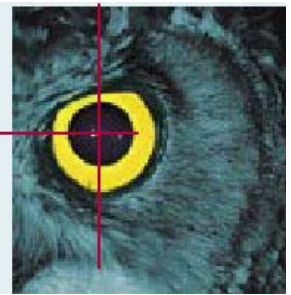

**4 Segment LED Ring Light - Illumination Unit**

**Order No. VM4-508Q**

Suitable for all OP1-M measuring objectives, with power supply and intensity control, 40 LEDs



**4 Segment LED Ring Light - Illumination Unit**

**Order No. VM4-509**

Suitable for all OP1-M measuring objectives, with power supply and intensity control, 80 LEDs



**4 Segment LED Ring Light - Illumination Unit remote controlled**

**Order No. VM4-507**

Suitable for all OP1-M measuring objectives, with power supply and intensity control, remote control unit for IMS/OMS software via USB/RS232



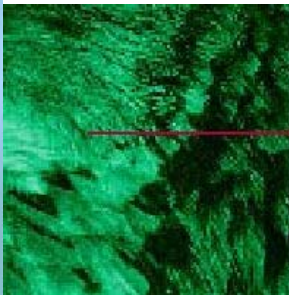

## Accessories

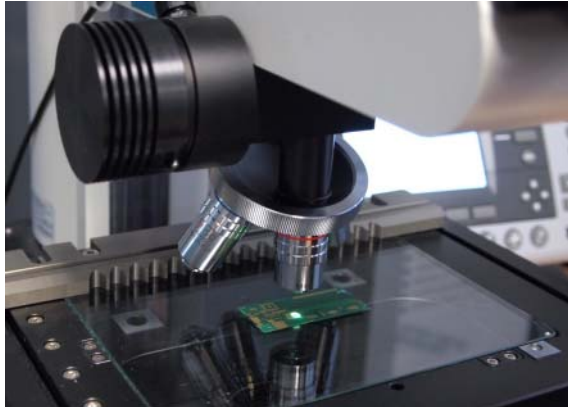

**Micro optical attachment for 4 micro objektives**

**Order No. VM3-3064**

Revolving attachment for 4 micro objectives 2:1 to 100:1



**Apochromatic incident light objectives, parfocalizing length 45 mm, RMS thread**

| Lens magnification | Total magnification | Field of view diameter | Numerical aperture | Free-working distance | Depth of focus (μm) | ~ Probing accuracy | Order-No.      |
|--------------------|---------------------|------------------------|--------------------|-----------------------|---------------------|--------------------|----------------|
| 2 : 1              | 20x                 | 9 mm                   | 0.04               | 5.8                   | 76                  | 5                  | <b>OP1-V2</b>  |
| 5 : 1              | 50x                 | 3.6 mm                 | 0.18               | 13.5                  | 8                   | 3                  | <b>OP1-V5</b>  |
| 10 : 1             | 100x                | 1.8 mm                 | 0.25               | 5.9                   | 4                   | 1.5                | <b>OP1-V10</b> |
| 20 : 1             | 200x                | 0.9 mm                 | 0.40               | 1.8                   | 2                   | 1                  | <b>OP1-V20</b> |
| 50 : 1             | 500x                | 0.36 mm                | 0.65               | 0.4                   | 1                   | 1                  | <b>OP1-V50</b> |
| 100 : 1            | 1000x               | 0.18 mm                | 0.95               | 0.5                   | 1                   | 1                  | <b>OP1-V99</b> |

### LED Ring Light



**Order-No. RL4-ALV**

Suitable for 5:1, 10:1 and 20:1  
OP1-AL and V Objectives, 16 LEDs

related power supplies:

Transformer with power supply

**TR7-N**

Transformer with power supply,  
remote controlled

**TR7-NU**





## Accessories

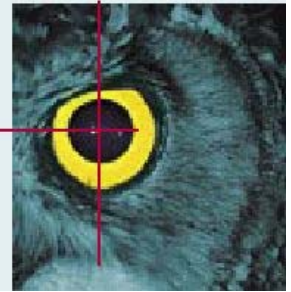

### Micro Optical Attachment for 4 micro objectives with extra long working distance\*

Order No. **VM3-306R**

Revolving attachment for 4 micro objectives 2:1 to 50:1 with integrated coaxial incident light



\*Reduces the maximum specimen height to 115 mm



### Apochromatic incident light objectives with extra long working distances, parfocalizing length 95 mm, RMS thread

| Lens magnification | Total magnification | Field of view diameter | Numerical aperture | Free-working distance | Depth of focus (µm) | ~ Probing accuracy | Order-No.       |
|--------------------|---------------------|------------------------|--------------------|-----------------------|---------------------|--------------------|-----------------|
| 2 : 1              | 20x                 | 9 mm                   | 0,06               | 35,6                  | 76                  | 5                  | <b>OP1-VX02</b> |
| 5 : 1              | 50x                 | 3,6 mm                 | 0,14               | 35                    | 14                  | 3                  | <b>OP1-VX05</b> |
| 10 : 1             | 100x                | 1,8 mm                 | 0,28               | 35                    | 4                   | 1.5                | <b>OP1-VX10</b> |
| 20 : 1             | 200x                | 0,9 mm                 | 0,42               | 20,2                  | 2                   | 1                  | <b>OP1-VX20</b> |
| 50 : 1             | 500x                | 0,36 mm                | 0,55               | 13,1                  | 1                   | 1                  | <b>OP1-VX50</b> |

Revision No: 04



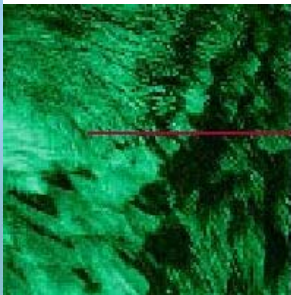

## Accessories



### Ring Light - Illumination Unit

Order No. **MS3-504**

Suitable for all OP1-VX objectives, with one fibre optic light guide.

For use in connection with cold light source VMP-GLL.



### LED Ring Light - Illumination Unit

Order No. **RL8-LED**

Suitable for all OP1-VX objectives, 16 LEDs

related power supplies:

Transformer with power supply

**TR7-N**

Transformer with power supply, remote controlled

**TR7-NU**





Revision No: 04



Technische  
Mikroskopie

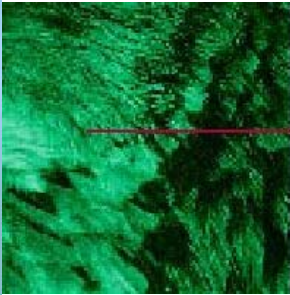

## Technical data

### Measuring Microscope VMM 150 main unit with measuring stage

|  |   |
|--|---|
| Main unit:   | solid aluminium cast  |
| Optics holder:   | guided roll bearing, coaxial coarse and fine focus;<br>optional Z-measurement (opto-electronic linear scale). |
| Movement range:  | 150 mm  |
| Measuring stages:  |   |
| Measuring range:   | 150 x 100 mm or 200 x 100 mm  |
| Guiding:   | roll bearing  |
| Movement:  | fast and fine adjustment  |
| Fasteners:   | 2 T-slots with measuring stage 150 x 100 mm   |
| Max. weight limit:   | 15 kg   |
| Measuring system:  | opto-electronic incremental steel scale   |
| Resolution:  | 0,0001 mm   |
| Accuracy limit for a<br>coordinate direction,<br>valid for working<br>temperature range: | $1.8 \mu\text{m} + 0.005 * L \mu\text{m}$   |
| Lighting:  | coaxial incident and transmitted LED illumination   |
| Light sources (accessories):   | with integrated stepless brightness control   |
| Light supply:  | integrated LEDs   |

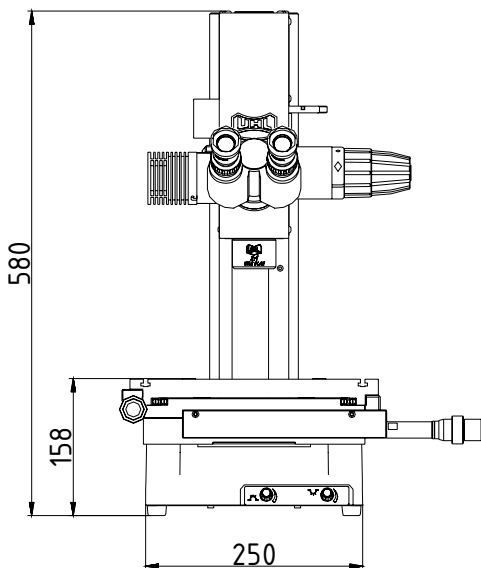

Dimensions VM3-BT01

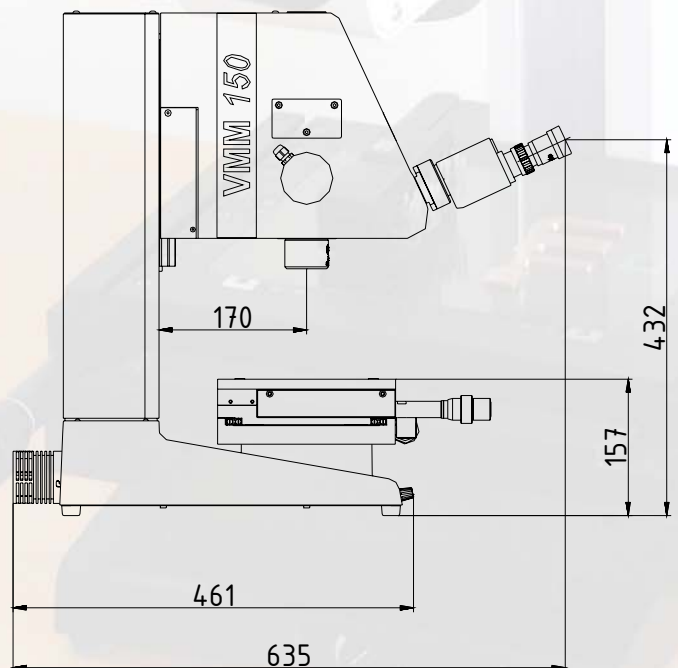



## Technical data

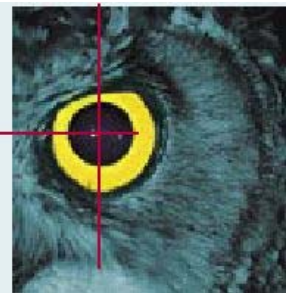

### Optical System

|                                    |                                      |
|------------------------------------|--------------------------------------|
| Measuring tube:                    | binocular with dioptric compensation |
| Eye-pieces:                        | 10x, with eye cups, (FOV18)          |
| Viewing angle:                     | 25 °                                 |
| Image:                             | upright and laterally true image     |
| Total magnification:               | see table for objectives             |
| Measuring objectives:              | changeable, telecentric ray path     |
| Measuring or video tube reception: | bayonet mount                        |
| Further technical data:            | refer to "Accessories"               |
| Micro objectives:                  | for viewing surface structures       |
| Technical data:                    | refer to "Accessories"               |

### General

|                        |                       |
|------------------------|-----------------------|
| Operating temperature: | 10° C to 40° C        |
| Working temperature:   | 20 +/- 0,5° C         |
| Storage temperature:   | -10° C to 60° C       |
| Power supply:          | 120/230 Vac, 50/60 Hz |
| Weight (net)           |                       |
| Main unit No.VM4-BT01: | 30 kg                 |

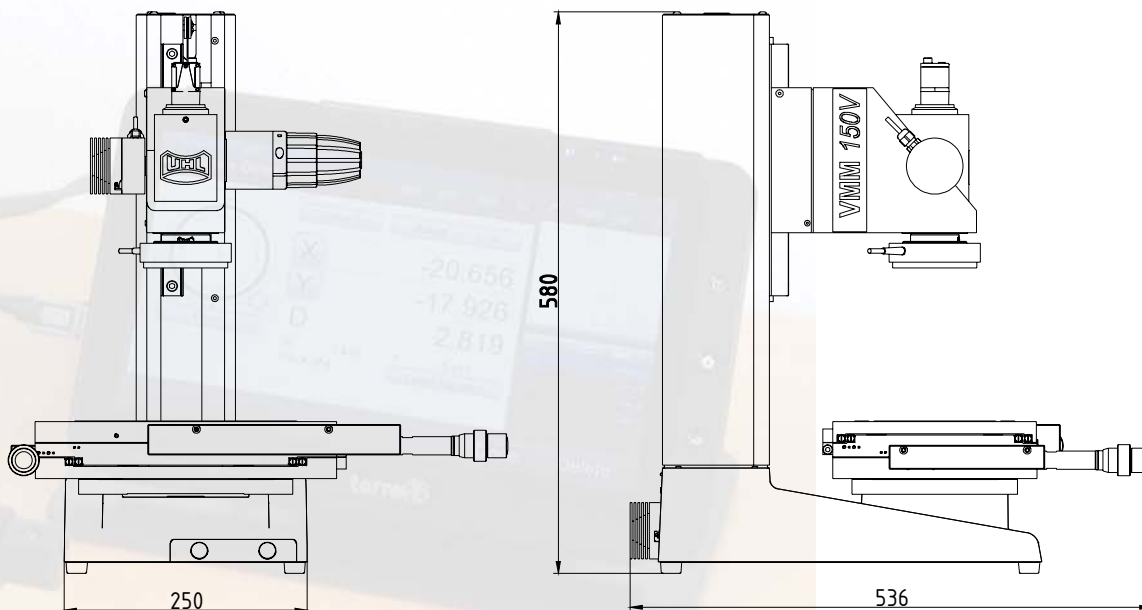

Dimensions VM3-VT01



Special designs and OEM models using parts of our component system are possible at any time:

Walter Uhl  
techn. Mikroskopie  
GmbH & Co.KG  
Loherstraße 7  
D-35614 Aßlar

Tel. (0 64 41) 8 86 03  
Fax (0 64 41) 8 57 18

[www.walteruhl.com](http://www.walteruhl.com)



Specifications are about to change without notice!



Technische  
Mikroskopie

[www.walteruhl.com](http://www.walteruhl.com)